



ROWASHER

ECO-FRIENDLY PARTS WASHERS

OPERATING MANUAL

ROZONE LTD

Queen Street, West Midlands,
United Kingdom, WS10 8JF
Tel: +44 (0)121 526 8181
E-mail: info@rozone.co.uk

ROZONE GmbH

Am Ölbach 44, D-33334 Güttersloh,
Deutschland
Tel: +49 (0)5241 9443 690
E-Mail: info.de@rozone.com



www.rowasher.com

**Change the ROWASHER Microbial Filter Mat EVERY MONTH
To Maintain Cleaning Performance**

**Change the ROWASHER MICROBIAL MAT EVERY MONTH
To Maintain Cleaning Performance**

Thank you for purchasing the Rozone ROwasher

The ROwasher is designed to safely and effectively remove oil and grease from industrial and automotive parts. It employs a clever technology called bioremediation to dramatically reduce waste fluid generation, reducing the expense of hazardous waste removal and bringing significant savings to the user. The ROwasher system comprises three distinct parts: The ROwasher machine, the ROWash Cleaning Solution and the ROwasher Microbial Filter Mat. The Filter Mat contains millions of micro-organisms. It releases these microbes into the ROwasher system to break down or "eat" the oil and grease that has been washed off dirty parts into the ROWash Cleaning Solution. The microbes turn it all into harmless carbon dioxide and water, leaving the ROWash Solution clean and strong for every use, effectively recycling the fluid and reducing the need for hazardous waste disposal. The ROWash Cleaning Solution is pH neutral, non-caustic, non-flammable and a biodegradable degreasing solution bringing health and safety benefits to the user and assisting compliance with latest workplace legislation.

This operating manual has been designed to give you all the information on the Rozone ROwasher.

Please read carefully before using the machine. Familiarise yourself with this unit's operation, its particular features and limitations.

Should you require any further information please call our Rozone Support Team on 0121 526 8181

ORIGINAL OPERATING INSTRUCTIONS

CONTENTS

1. Safety Instructions
2. Power Connection
3. Proper Use
4. Function
5. Machine Diagram and Parts
6. Setting Up
7. Operation
8. Energy Saving Mode
9. Control Box Diagram – Normal Operation
10. Maintenance and Care
11. Shutting Down
12. Restarting
13. Moving or Transporting
14. Maintenance and Repair
15. Trouble Shooting Guide
16. Accessories and Spare Parts
17. Warranty
18. Disposal Information
19. Environmental Protection
20. CE Declaration and P.A.T. Testing
21. Electrical Box Diagram

Change the ROWASHER Microbial Filter Mat EVERY MONTH To Maintain Cleaning Performance

1. SAFETY INSTRUCTIONS

Every person who works with this machine must be familiar with the content of the operating instructions prior to use. These instructions are part of the unit and must be available to operating staff at all times. Please read the operating instructions for your ROwasher before using it.

The unit should only be operated by those authorised to do so. Warning information on the machine provides important directions for safe operation. Misuse of the ROwasher will affect the safe operation of the machine.

This appliance can be used by children aged from 8 years and above and persons with reduced physical, sensory or mental capabilities or lack of experience and knowledge if they have been given supervision or instruction concerning use of the appliance in a safe way and understand the hazards involved. Children shall not play with the appliance. Cleaning and user maintenance shall not be made by children without supervision.

In addition to the information contained in the operating instructions, all statutory safety and accident prevention regulations must be observed.

The operating noise level of this machine is below 70dB(A).

Key to Safety Instructions



Warning Symbol - You will find this symbol next to all safety instructions relating to damage prevention. Take caution to avoid personal injury or material damage.



Prohibition Symbol – You will find this symbol next to all prohibition instructions where failure to comply could result in direct personal injury and damage to material. It is mandatory to comply with these instructions

2. POWER CONNECTION



The voltage indicated on the machine base control box label must correspond to the voltage of the electrical source.



Safety class 1 – Appliances may only be connected to sockets with proper earthing.

Change the ROWASHER MICROBIAL MAT EVERY MONTH To Maintain Cleaning Performance



It is recommended that you connect this device to a socket that has a 30mA RCD device guard against earth leakage faults.



Make sure the power cord is not damaged by running over, pinching, dragging or similar. Protect the cable from heat, oil and sharp edges. If the power cord is damaged do not use. Damaged supply cords increase the risk of electric shock. The cable should only be replaced by an approved Rozone Ltd Service Expert



Never touch the mains plug with wet hands

3. PROPER USE



The ROwasher is designed for manually cleaning parts with a maximum weight of 150kg for the Static & Mobile ROwasher and 200kg for the XL ROwasher. Do not exceed the specified weight.



ROwash Cleaning Solution and ROwasher Microbial Filter Mat must be used for the ROwasher system to function properly. The use of other detergents or cleaning fluids can hamper or prevent the bioremediation of oil and greases and invalidate the warranty.



Do not fill the tank with solvents, flammable or explosive liquids.



The ROwasher is not meant for the disposal of used oil. If large quantities of oil, petrol, engine oil, anti-freeze agents or similar substances are added to the system this can hamper the bioremediation of oil and grease by the microbes



Do not clean paint brushes or painting tools in the ROwasher or any materials containing asbestos or other hazardous substances such as pesticides.



The machine should only be used by people who have been instructed in how to use it properly.



The operator must use the machine as instructed in this manual. The operator must pay attention to any surrounding hazards and consider those working around him when using the ROwasher.



The machine must be checked prior to use to ensure that it is in proper working order and is operating safely.



All electrical equipment in the working area must be protected against any spraying cleaning solution.

Change the ROWASHER Microbial Filter Mat EVERY MONTH To Maintain Cleaning Performance



Please wear appropriate PPE when using the machine – such as safety goggles and protective gloves.



If the cleaning solution comes into contact with the eyes, please rinse the eyes thoroughly with water. If swallowed please consult a doctor immediately.

4. FUNCTION

The microbes are first introduced to the system in the ROWasher Microbial Filter Mat and are then transported by the ROWash Cleaning Fluid through the filter mat into the ROWasher tank

The cleaning fluid in the tank is heated by the element and transported by the pump to the sink where it is dispensed through the nozzle and flo-thru brush. The cleaning fluid must remain heated for the microbes to function properly.

Solid dirt particles washed off parts into the sink are captured in the filter basket in the sink tray and in the underlying ROWash Microbial Filter Mat which traps large particles of grease and oil along with any particulate matter larger than 50 microns.

Grease and oil is washed off parts into the ROWasher tank and then degraded by the microbes into carbon dioxide and water.

Change the ROWASHER MICROBIAL MAT EVERY MONTH To Maintain Cleaning Performance

5. MACHINE DIAGRAM AND PARTS

1. Sink Top
Part No. 11090802 XL : 11090804
2. Nozzle
Part No. 11090857
3. Brush
Part No. 11090855 XL : 11090856
4. Filter Support Grid
Part No. 11090826
5. ROWASHER Microbial Filter Mat
Part No. 11030409
6. Sink Tray
Part No. 11090805 XL : 11090806
7. Basket Filter Part No. 11090538

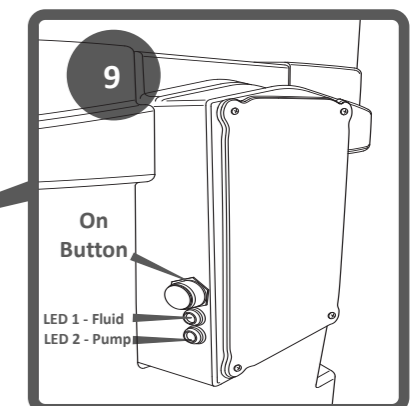
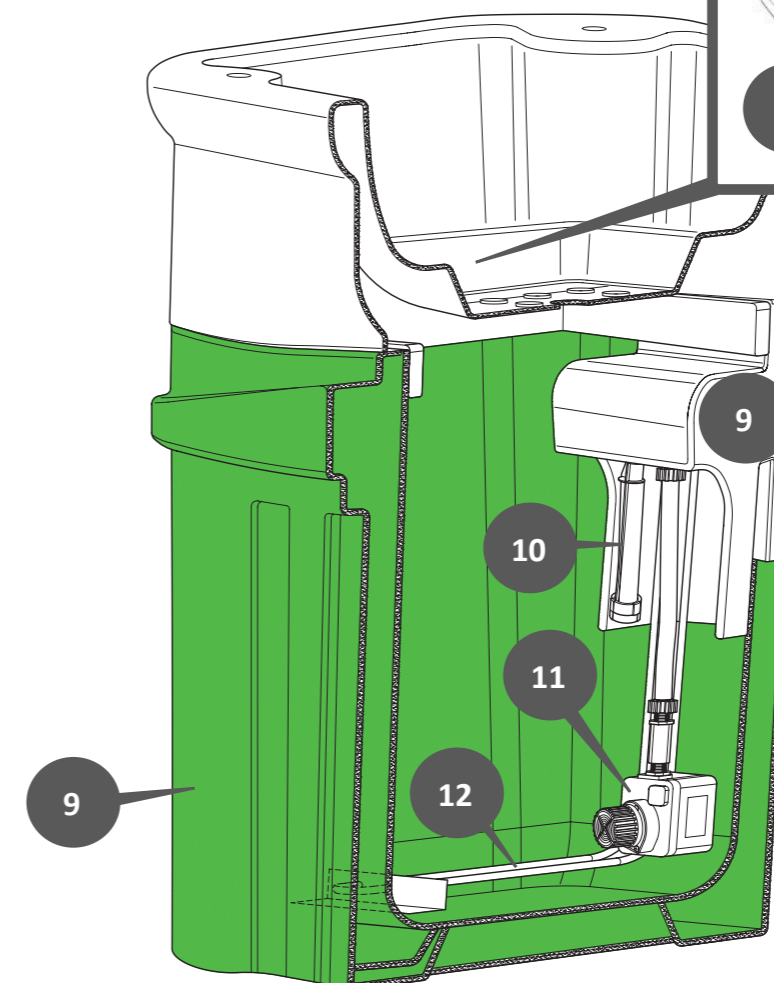
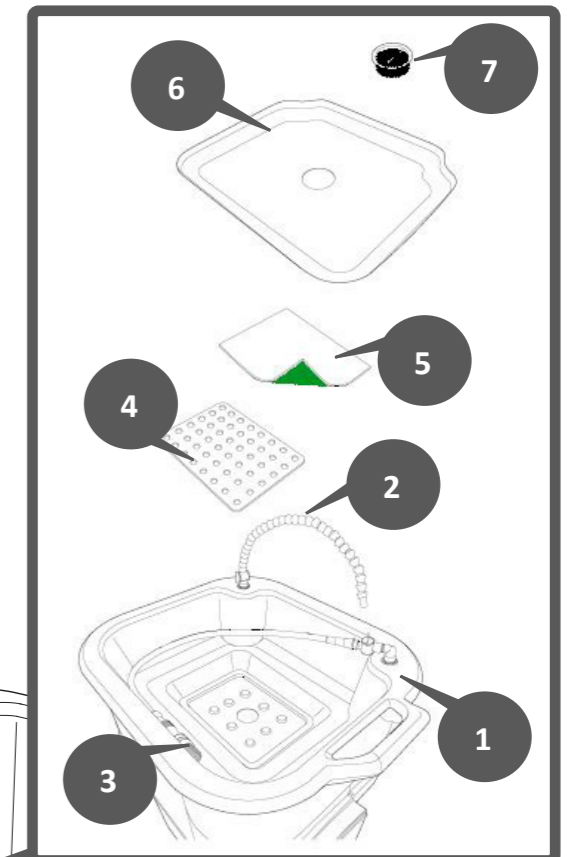

8. ROWASHER Tank Base
Mobile: 11090800
Static / XL: 11090807
9. Control Box
Part No. 11090803
10. Fluid Sensor
Part No. 11090840
11. Pump
Part No. 11090878
12. Heater
Part No. 11090828

Change the ROWASHER Microbial Filter Mat EVERY MONTH To Maintain Cleaning Performance

6. SETTING UP



After removing packaging, check the unit for transport damage. If any defect is detected do not connect the machine to the mains. Report damage to vendor.



Situate the ROWasher on flat stable ground. The floor must be even to ensure safe operation.

Press the wheel brakes on the rear of the machine

Remove the black sink tray

Unpack the ROWash Microbial Filter Mat and place it white side up on top of the filter support grid

Replace the black sink tray on top

Pour 60 litres of ROWash Cleaning Solution slowly into the sink



Do not overfill



WARNING – Adding any other cleaning solution or liquids such as solvents, disinfectants and alkaline cleaners can deactivate the microbes and the bio-remediation of grease and oil will be affected resulting in the ROWasher not working properly.



Plug into the correct mains supply. To avoid damage, the machine must be plugged into the power source stated on the machine control box label. Switch on electrical supply

The ROWasher will begin to heat up the cleaning solution to its optimal working temperature of 42°C. (This will take approx. 4 hours)

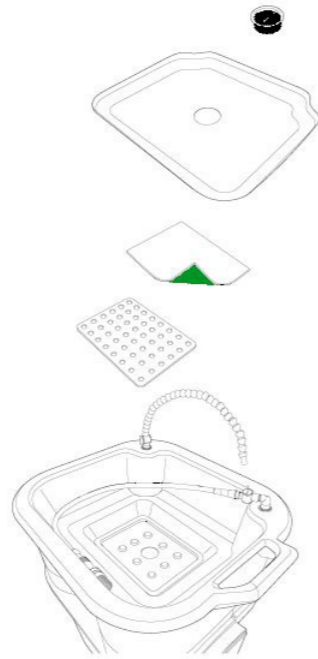

Change the ROWASHER MICROBIAL MAT EVERY MONTH To Maintain Cleaning Performance

7. OPERATION



Cleaning is a manual operation using the flo-thru brush in the ROWasher sink top

Wear appropriate PPE such as safety goggles and protective gloves



Place the dirty parts in the sink tray (maximum weights must not be exceeded – see 3. PROPER USE)

Press the green button to turn the pump on. Wet the sink, nozzle and brushes prior to cleaning to prevent grease and dirt sticking to the surfaces. The pump will run for 5 minutes and then automatically switch off.

Open the tap of the desired tool – you can use both the nozzle and the flo-thru brush at the same time for maximum cleaning if desired.



Note: Any parts susceptible to corrosion should not be left in sink after cleaning



As with all partwashers excess grease and oil should be disposed of prior to washing. DO NOT USE THE ROWASHER AS A WASTE DUMP



Do not turn the ROWasher off unless it is for safety reasons, moving or servicing. The optimum temperature for the activity of the microbes and therefore breakdown of oil and grease is between 37°C and 42°C, therefore the ROWasher must always be left switched on.

8. ENERGY SAVING MODE

After a 4 hour period of inactivity the ROWasher automatically switches to energy saving mode (37°C) and remains at this temperature until the pump is restarted when it will return to 42°C

**Change the ROWASHER Microbial Filter Mat EVERY MONTH
To Maintain Cleaning Performance**

**Change the ROWASHER MICROBIAL MAT EVERY MONTH
To Maintain Cleaning Performance**

9. OPERATIONAL GUIDE FOR CONTROL BOX

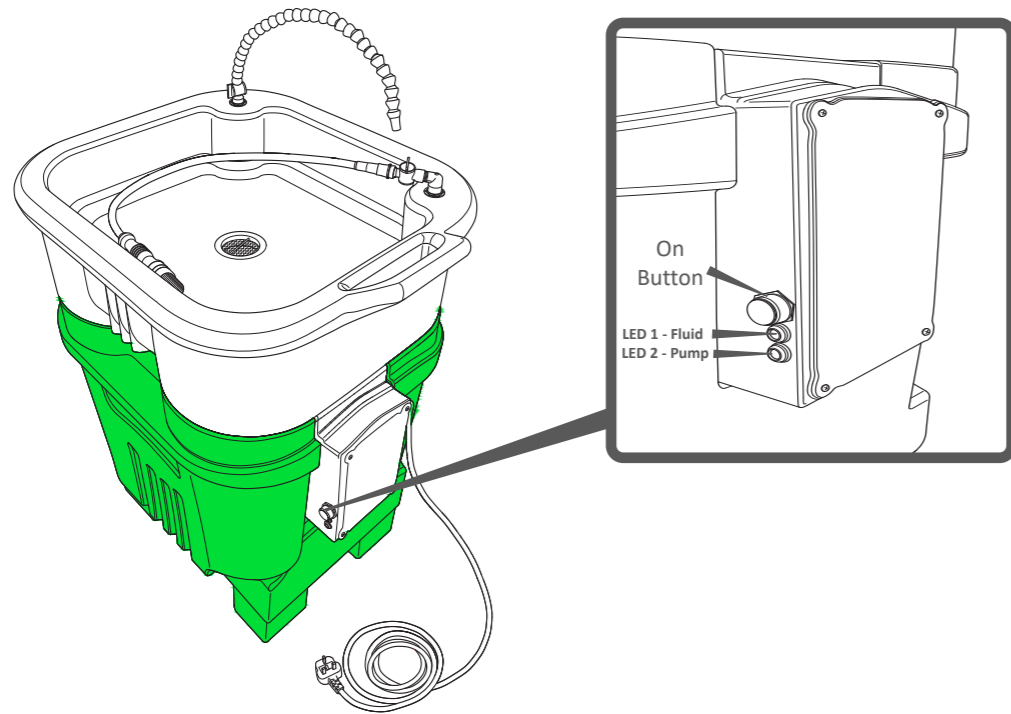

10. MAINTENANCE AND CARE

DAILY

Check to see if the red “LOW FLUID” indicator light is flashing

If the red “LOW FLUID” light is flashing, pour 20 litres of ROWash Cleaning Solution into the ROWasher sink



NOTE – Do not overfill the ROWasher.

If the red “LOW FLUID” indicator light is flashing the heater element in the base unit will be switched off and the cleaning solution will begin to lose temperature. Therefore it is important to top up the fluid as soon as possible to keep the microbes at their optimum working temperature

MONTHLY - Change the Filter Mat

First remove the sink tray

Wring out the fluid from the old Filter Mat into the sink

Please dispose of used Filter Mat according to local authority regulations for waste containing mineral oil (see “Instructions for Disposal”)

Place new ROWasher Microbial Filter Mat white side up onto the filter support grid

Replace the sink tray

YEARLY - Annual maintenance check on the Rowasher recommended

If a cleanout and change of fluid is required please follow correct procedure

Ensure the machine is switched off and unplugged from the mains

Lift off the sink top and disconnect hose pipes

Remove dirty solution from the base unit and dispose of waste according to local authority regulations (see “Instructions for Disposal”)

Rinse / jetwash the base unit

Replace sink top checking that the hose pipes are all connected

Remove sink tray

Place new ROWasher Microbial Filter Mat white side up on the filter support grid

Replace sink tray

Pour 60 litres of new ROWash cleaning solution into the sink

No:	Output			Description	Notes
	LED 1 FLUID	LED 2 TEMP	Sound		
1	Flashing Yellow	Flashing Yellow	Beep	Indication of successful initialisation stage.	Initialisation sequence will start immediately after machine is powered on. At the end of successful initialisation the Sounder and two LEDs are activated and should be observed for one second. Any other colours or no sound at this point is an indicator of a problem.
2	Solid Green	Solid Green	No	Normal Mode 42°C active. Liquid level is OK.	Normal operation.
3	Solid Green	Solid Yellow	No	ECO Mode 37°C active. Liquid level is OK.	Normal operation.

Change the ROWASHER Microbial Filter Mat EVERY MONTH To Maintain Cleaning Performance

11. SHUTTING DOWN

Switch the power off at the electrical socket.



NOTE – In order for the bioremediation process to occur the temperature of the cleaning solution must be maintained at 42°C for the microbes to operate at their optimal level. Therefore the ROWasher must remain plugged in at all times. The power supply must not be switched off at night or at weekends.

12. RESTARTING



If there is a power failure or the machine is switched off for a considerable length of time and the cleaning solution is allowed to go cold, new microbes will need to be added to the cleaning solution.

Replace the Filter Mat (see section “Maintenance and Care/Monthly”)

13. MOVING OR TRANSPORTING



Unplug the ROWasher from the electrical socket ; roll up the power cord. Take off brakes. Carefully wheel to desired location taking into account the influences of the surrounding area and ground conditions to ensure the ROWasher does not tip over.



Do not expose the appliance to rain or snow and do not use it in damp or wet conditions to ensure safe operation.

When finished wheel ROWasher to desired location and plug the power cord back into the appropriate electrical socket to avoid deterioration of cleaning performance (see section “Restarting”)



Do not abuse the supply cord and/or the hose. Never use the supply cord or hose to carry or pull the appliance. Damaged supply cords increase the risk of electric shock.

14. MAINTENANCE AND REPAIR



Switch off the ROWasher and unplug from mains socket before carrying out any maintenance on the machine.



Please wear appropriate PPE such as safety goggles and gloves.



Repair work should only be carried out by an approved Rozone Ltd Service Expert.

Change the ROWASHER MICROBIAL MAT EVERY MONTH To Maintain Cleaning Performance

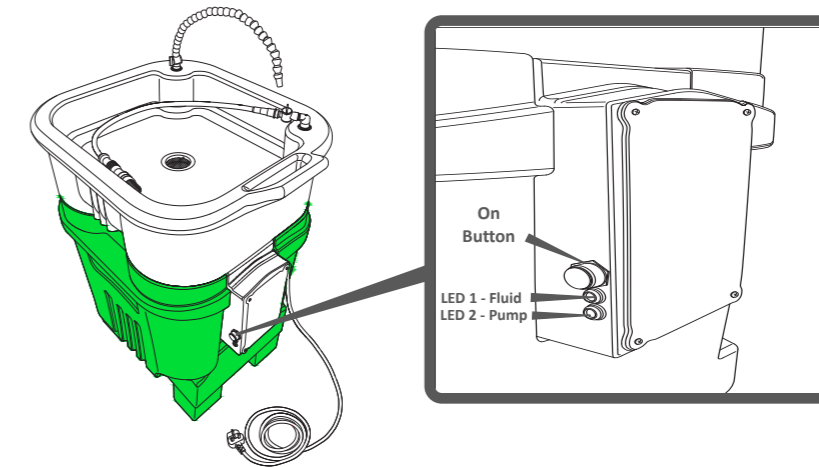

15. TROUBLESHOOTING GUIDE

No:	Output			Description	Notes
	LED1	LED2	Sound		
Problem Indicators					
Solution					
4	Flashing Red every second	Solid Green or Yellow	Beep	Liquid level is too low. Application stopped, heater and pump are disabled.	a) Check fluid level. b) Check level sensor position. c) Replace sensor unit.
5	Both Flashing Red for 3 seconds then 2 seconds OFF		Beep	Liquid level is too high. Application stopped, heater and pump are disabled.	a) Remove some fluid down to allowed level. b) Check level sensor position. c) Replace sensor unit.
6	Both Flashing Red for 4 seconds then 2 seconds OFF		Beep	No response from sensor. Application stopped, heater and pump are disabled.	a) Check sensor connection. b) Replace sensor unit.
7	Both Flashing Red for 5 seconds then 2 seconds OFF		Beep	No temperature rise has been detected. Application stopped, heater and pump are disabled.	a) More liquid added while device was active? b) Restart unit. Check fuses. c) Replace sensor unit. Heater element requires replacement.
8	Both Flashing Red for 6 seconds then 2 seconds OFF		Beep	Critical liquid temperature - above 48C.	a) Initial liquid temperature too high. b) Faulty heater relay. c) Restart unit. Check fuses. d) Replace sensor unit. Heater element requires replacement.
9	Solid Green	Solid Red or Yellow	No	Pump is not working after button was pressed.	a) Check pump connection. b) Check pump fuse.
10	OFF	OFF	No	No signs of activity when unit is powered on for more than a minute.	a) Check power connection. b) Check PSU fuse. c) Control unit requires replacement.

**Change the ROWASHER Microbial Filter Mat EVERY MONTH
To Maintain Cleaning Performance**

**Change the ROWASHER MICROBIAL MAT EVERY MONTH
To Maintain Cleaning Performance**

16. ACCESSORIES AND SPARE PARTS



Only use accessories and spare parts which have been approved by Rozone Ltd. This ensures that the ROwasher operates correctly and safely.

17. WARRANTY

We will repair all machine appliance failures within the warranty period free of charge, provided that the failure is caused by faulty parts or defects in fabrication.

In the event of a warranty claim please contact your dealer

18. DISPOSAL INFORMATION

Dispose of waste according to local authority regulations. The following EC waste codes are applicable to the ROwasher Microbial Filter Mats and ROWash Cleaning Solution

EU WASTE CODE	ROWASHER PRODUCT
130899 Oil Waste a.n.g.	FILTER MAT
070601 Watery Wash Liquids	ROWASH CLEANING SOLUTION

19. ENVIRONMENTAL PROTECTION

	The packaging material can be recycled. Please do not place the packaging into the ordinary bin for disposal, arrange for proper recycling
	Old appliances contain valuable materials that can be recycled. Please arrange for the proper recycling of old appliances. Batteries, oil and similar substances must not enter the environment. Please dispose of your old appliances using appropriate collection systems.

WEE Producer Registration Number – WEE/JG0549ZR/PRO

20. CE DECLARATION

We hereby declare that the machines stated below comply with the relevant basic health and safety requirements of the EU Directive, both in their basic design and construction and in the version put into circulation by us. This declaration shall cease to be valid if the machine is modified in any way without prior approval.

PRODUCT	Machine designed for parts cleaning using water based cleaning solutions
Type	ROwasher
Relevant EU Directives	2014/35/EU 2014/30/EU
Applied Harmonized Standards	EN61000-6-2:2005 EN61000-6-4:2007 EN60335-1:2012 EN61000-3-2:2014 EN61000-2-3:2013 +A11:2014 IP65

P.A.T. TESTING

The ROwasher machine is of a CLASS 1 construction and due to the weight of the machine when full should be classed as stationary. We recommend a minimum time of 12 months for combined testing and inspection and monthly for the formal visual inspection

EARTH CONTINUITY

Lift the sink and place out of the way allowing access to the heater element. Place the earth clamp of the P.A.T. tester onto the heater element and take readings as normal (use the 25amp setting for this test). The heater effectively earths the fluid in the base of the machine.

EARTH LEAKAGE

A 500v Insulation Test has been carried out on manufacturing of this machine.

If a machine fails the 500v Insulation Test whilst in service a second test may be carried out with the setting reduced to 240v

Change the ROWASHER Microbial Filter Mat EVERY MONTH To Maintain Cleaning Performance

21. ELECTRICAL BOX DIAGRAM

